

SAF-T Egress

Manual Egress option on High Performance Doors

For interior rooms that are sealed with Dynaco M2-Power, D-501, D-311 Slimline and D-313 Streamline doors, a manual egress option is offered. With this option, the Dynaco high performance door can serve as a means of egress as defined by the International Building Code. Even with this option, the Dynaco door remains durable enough to withstand industrial applications, yet easy enough for a child to use.

Emergency Egress Option provides a true means of Egress as stipulated by NFPA 101 Life Safety Codes and OSHA Standard 1910.36.



- **Panic safe use**
The user does not require special training, tools or prior knowledge to use the door.
- **Push opening**
The door is side hinged and opens in the direction of egress. No upward or horizontal sliding action with potential for failure or reliance on complicated counterweight and pulley systems.
- **Low operating force**
The egress option requires less than 30 lbs. of force to fully open the door.
- **Hazard free movement**
There are no thresholds or trip hazards to impede human movement; and the door requires a minimal amount of force to open.
- **Integrated control system**
Special controls will need to be built into the control box. These controls work with the egress sensor to stop the door when egress is opened.



2015 International Building Code compliance

Code Requirement	Dynaco Egress Option Compliance
<p>1010.1.1 Size of Doors The required capacity of each door opening shall be sufficient for the occupant load thereof and shall provide a minimum clear width of 32 inches (813 mm). The height of door openings shall be not less than 80 inches (2032 mm).</p>	<p>With the egress feature open, the width of the path of travel will be as wide as the width of the structural opening less 1.3 feet. The height of the egress feature is set at 80" for all door types.</p>
<p>1010.1.2 Door swing Egress doors shall be of the pivoted or side-hinged swinging type. Exception # 7. Power-operated doors in accordance with Section 1010.1.4.2. Power-operated doors. Where means of egress doors are operated or assisted by power, the design shall be such that in the event of power failure, the door is capable of being opened manually to permit means of egress travel or closed where necessary to safeguard means of egress. The forces required to open these doors manually shall not exceed those specified in Section 1010.1.3, except that the force to set the door in motion shall not exceed 50 pounds (220 N). The door shall be capable of swinging open from any position to the full width of the opening in which such door is installed when a force is applied to the door on the side from which egress is made.</p>	<p>Dynaco doors do not swing.</p> <p>Dynaco doors comply with Exception #7</p> <p>Dynaco doors with the Egress option are capable of being opened manually to permit means of egress or closed manually to safeguard means of egress.</p> <p>The force required to manually open the Egress is 28 pounds.</p> <p>The Egress option allows the door to open to the full width of the opening when a force is applied to the door on the side from which egress is made.</p>
<p>1010.1.9 Door operations. Except as specifically permitted by this section, egress doors shall be readily openable from the egress side without the use of a key or special knowledge or effort.</p>	<p>The zipper is not locked and can be immediately released upon impact. The egress impact spot is well marked with iconic indicators.</p>
<p>1010.1.9.1 Hardware. Door handles, pulls, latches, locks and other operating devices on doors required to be accessible by Chapter 11 shall not require tight grasping, tight pinching or twisting of the wrist to operate</p>	<p>A simple push on the marked spot opens the door. Any part of the body can be used and egress can be accomplished even in a panicked state.</p>
<p>1010.1.9.2 Hardware height. Door handles, pulls, latches, locks and other operating devices shall be installed 34 inches (864 mm) minimum and 48 inches (1219 mm) maximum above the finished floor.</p>	<p>The egress impact spot in the zipper is located between 40 – 42 inches above finished floor.</p>

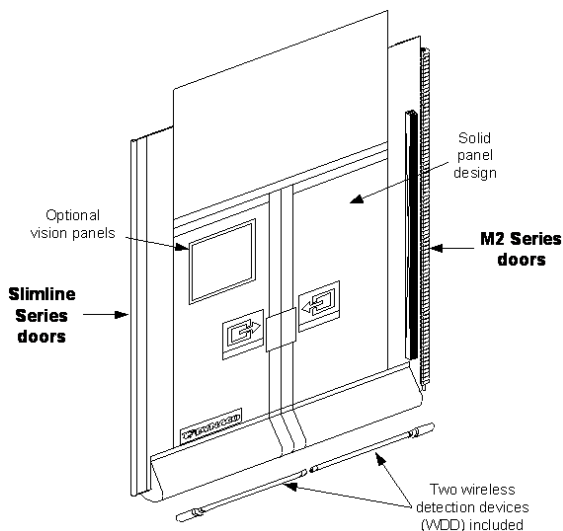

Dynaco Saf-T Egress Option: A T-shaped cut divides the door panel into 3 sections. The sections are held together by zippers. This allows the sections to release creating an emergency exit, simply by pushing at the indicated spot. The zipper is designed to break-away so it can immediately be released with minimal force. The dimensions of the egress passage are always 6.7ft high, with a standard width of door width minus 1.3ft. The passage width will vary with door installation.

Note: a fore-frame should be installed to prevent the zipper from brushing against the lintel during operation.

www.dynacodoor.us

Entrematic
935 Campus Drive
Mundelein, IL 60060
tel: 1-800-459-1930
info@dynacodoor.us

© Entrematic Group AB, 2018